

Weld and Grind smooth to .125 radius both sides

FRONT SIGHT BASE

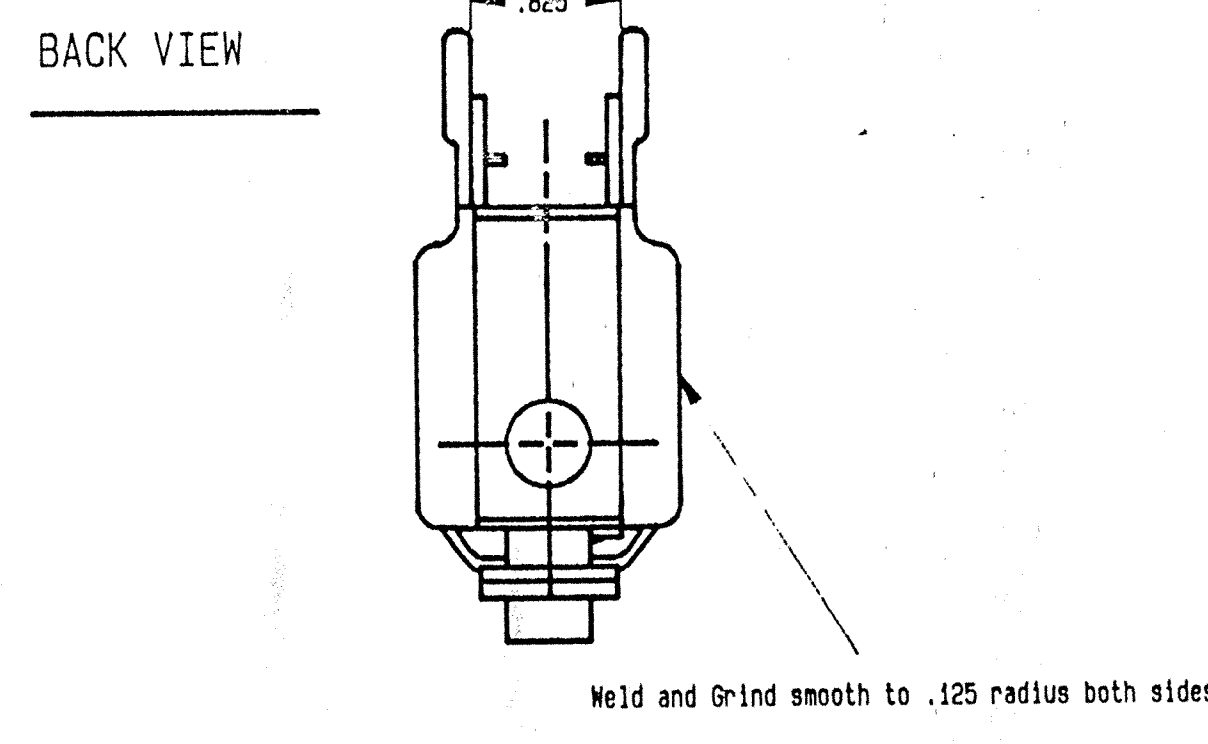

Weld and Grind smooth to .125 radius both sides

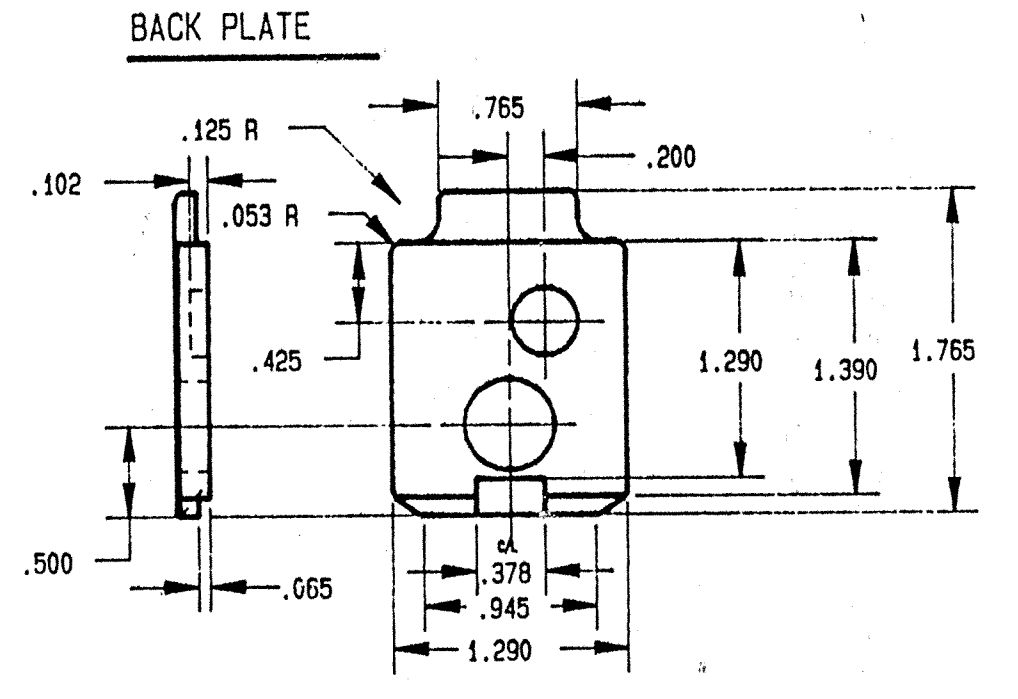
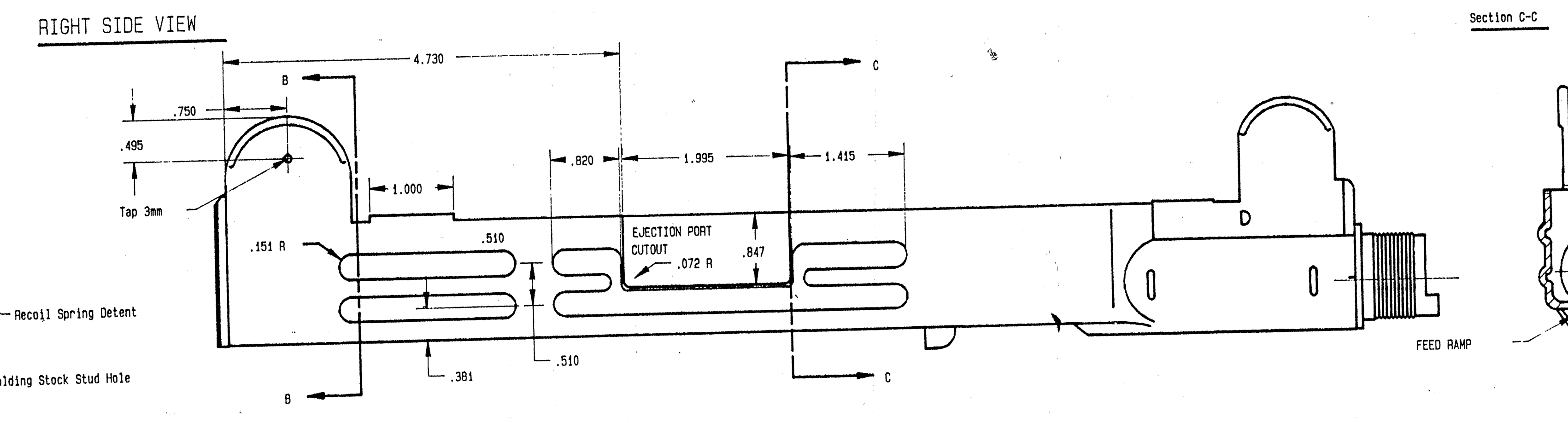
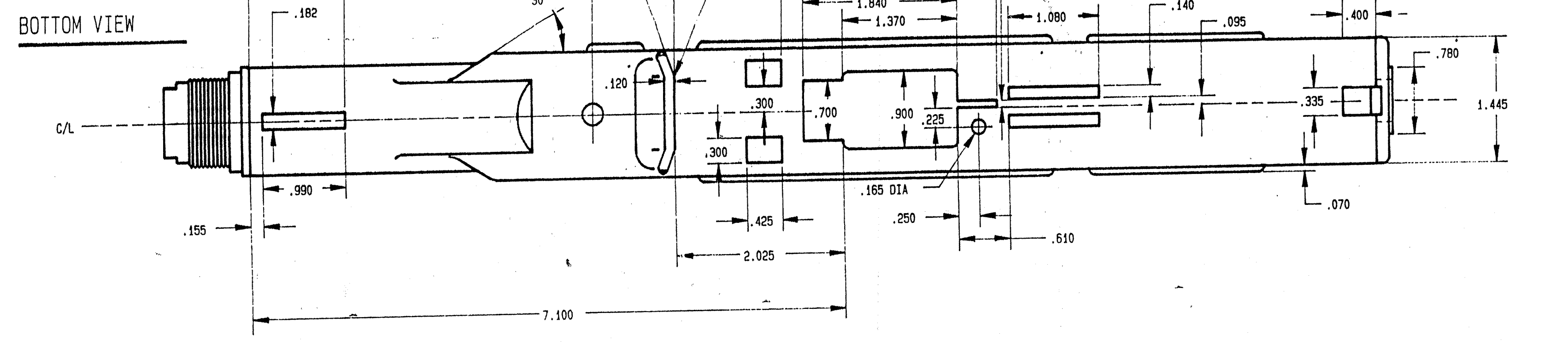
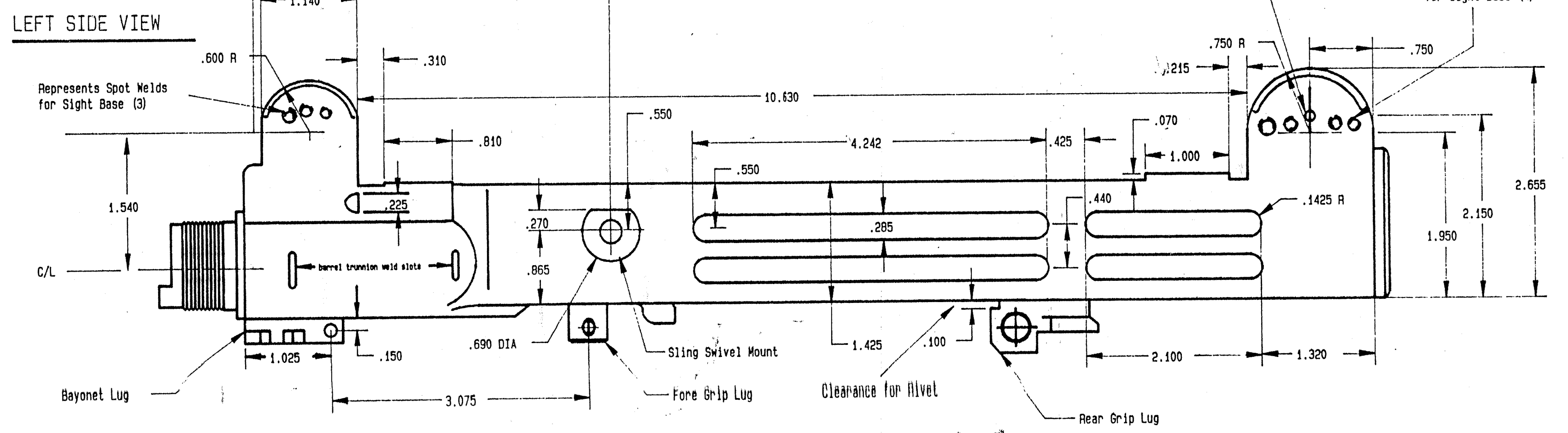
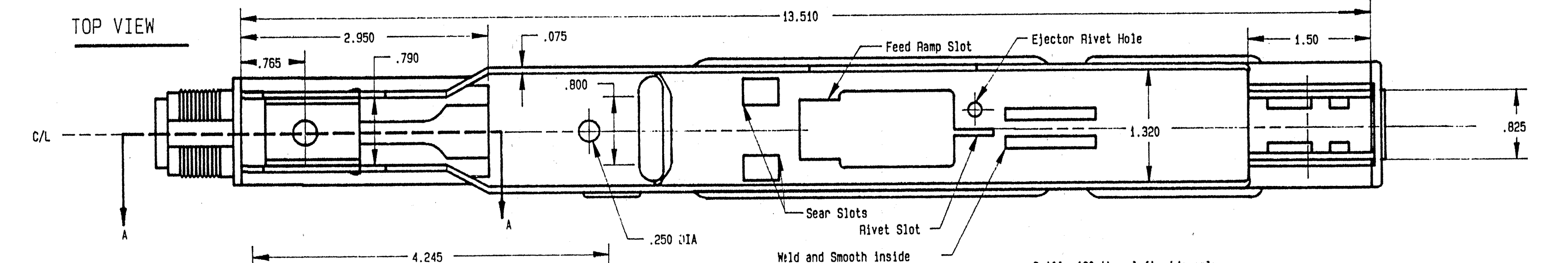
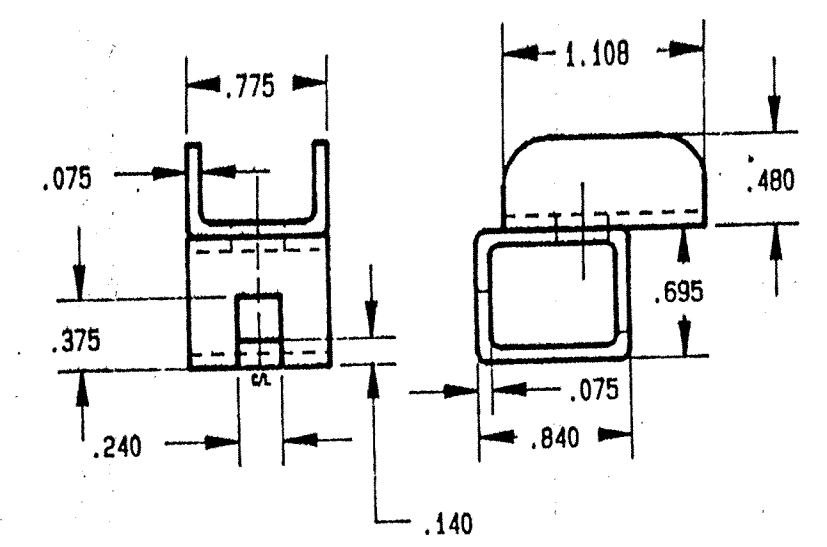
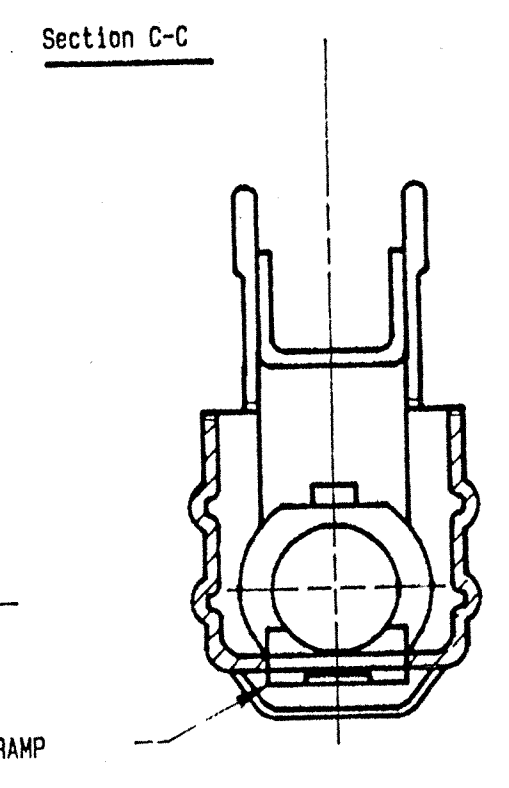
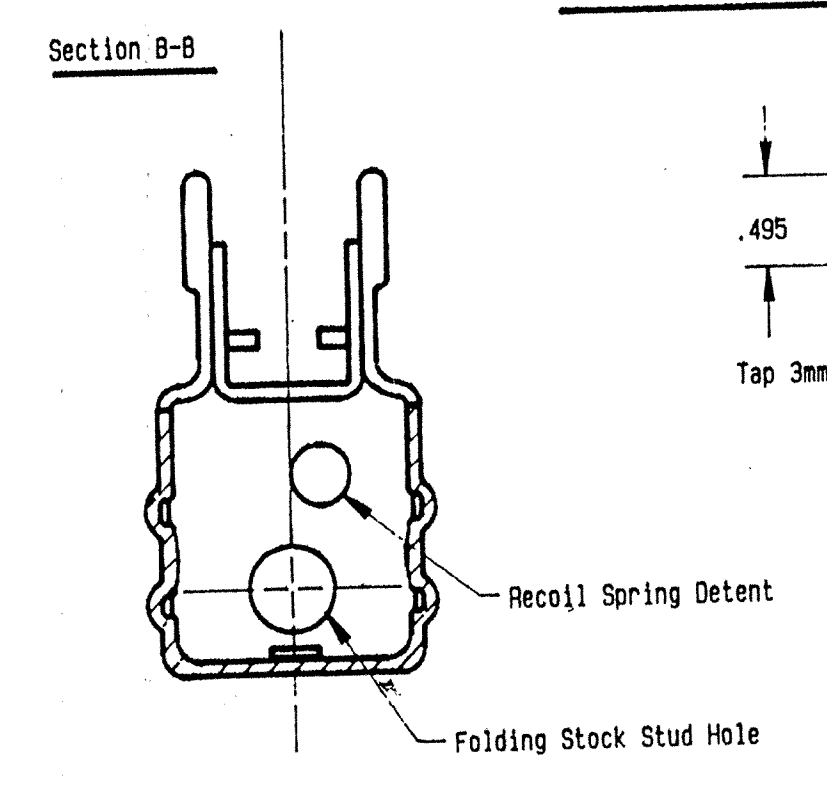
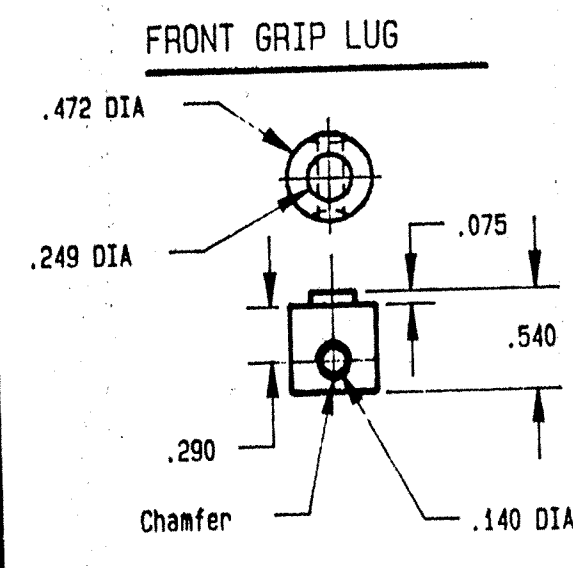
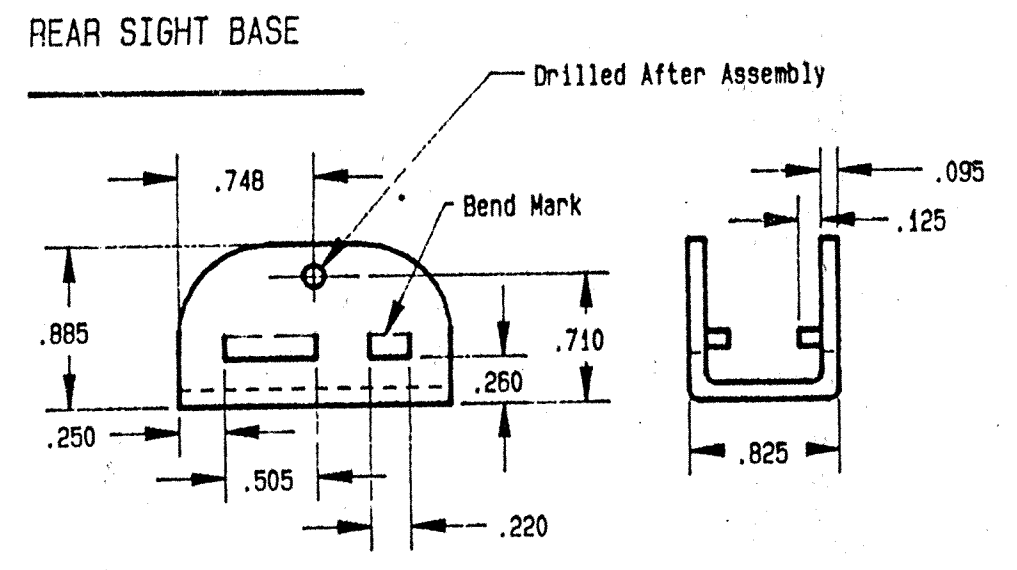

UZI SMG RECEIVER	
TOLERANCES: .X +.5 .XX +.10 .XXX +.010 ANGLES ± 0.5 Degrees	MATERIAL: 1018 MILD STEEL STAMPING
SIZE D	FINISH: PARKERIZE SCALE: 1:1
DO NOT SCALE DRAWING DIRECTLY	
SHEET 1 0	